



HAPPY 50TH BIRTHDAY GIESE ELEMENTARY SCHOOL

To our returning families, welcome back! To our new families, welcome to Giese Elementary! The Staff and I are extremely excited to get the year started and hit the ground running. There are some very exciting things getting ready to happen this year!

Let me begin by first introducing myself. My name is Tom Hyland and I am the Directing Principal for Giese. I bring over 15 years of educational experience to Giese. I am excited to be a part of the Giese Cheetah family and I am looking forward to meeting all of you.

We have had a lot of work done over the summer at Giese. We have new door ramps placed at every door. We had a lot of asphalt work done around the building and in the "bus drop off" area. We have expanded our parent drop off area in the front of the school. We also had our parking lot seal-coated. We didn't forget about the inside. We had 2 of our bathrooms updated, new doors placed on the East and West learning centers, as well as a brand new gym floor. The place looks great. I want to personally thank Mr. Arndt, our head engineer, for coordinating all of these efforts.

Like last year, we are focusing on increasing your child's reading abilities. Our first effort will focus on improving of your child's *Independent Reading Time*. This year, all Giese students will be assessed at the beginning of the year to determine their Independent Reading Level per the Fountas and Pinnell Leveling System. Your child's level will come in the form of a letter (A-Z). When your child receives their letter, they will then choose books to independently read at that level. This will ensure that the books they are reading at school and home are books that they can read successfully and comprehend. Your child will then be assessed around January and once again in June. The goal is to see every child increase their Independent Reading Level and continue on the journey to becoming life-long readers. (A chart titled *Fountas and Pinnell Text Level Ladder of Progress* has been attached to this newsletter to better explain what your child's letter will mean.). Please read with your child 20 minutes a night. This will make them better readers.

A second effort will find our Teaching and Learning Staff incorporating *The Daily Five* into their Literacy Blocks. *The Daily Five* is a structure that will help students develop the daily habits of reading, writing, and working with peers that will lead to a lifetime of independent literacy. We will begin incorporating *The Daily Five* in our classrooms during third quarter.

We need your help this year and aren't afraid to ask for it. Please consider filling out a WINGS approval form and sending it back to school with your child. Once the district approves you, please let your child's teacher know that you are interested in helping us out. Past volunteers have helped create bulletin boards, copied papers for teachers, tutored students in literacy and math, and helped assist teachers with Reading and Math Centers. Also, please consider dropping in at one of the monthly PTA meetings (dates to be sent home at a future date). Joel Schroeder is currently our PTA Treasure. He could certainly use a couple of extra set of hands this year with all of our planned PTA activities.

FOR THE SAFETY OF OUR CHILDREN, please do not utilize the Giese Staff Parking Lot as a loading/unloading zone with your child. It can be very dangerous, especially for the younger children. Please note the new "DO NOT ENTER" signs on the west end of the Parking lot. This is an "EXIT ONLY" now. You must use the driveway on the east end to enter the parking lot for Giese School. Also, please do not park in the front turnaround as the busses and daycare vans need this space to safely load and unload their passengers. I thank you, in advance, for your cooperation.

I hope that your child's 2015-2016 school year is the best one yet. Should you have any concerns or questions, I can be contacted at 664-8252 or via email at thomas.hyland@rusd.org. I look forward to getting to know you and your child throughout the year!

Respectfully,

Thomas Hyland

Directing Principal - Giese Elementary

"The BEST kept secret in RUSD!"

EMERGENCY CARDS...Please fill out the green card in your 1st day folder and return it to school by Friday, September 4, 2015. The first homeroom with 100% of the green cards turned in will receive a special prize from the office!!! It is very important that we have an emergency card for every child on file. Please remember to include your e-mail address as we will be utilizing them often this year.

SCHOOL SCHEDULE...A copy of the school schedule is enclosed. Please note that school begins at 8:00 a.m. and ends at 2:45 every day. There is no supervision on the playground before 7:50 a.m. Please do not drop your child off before that time. If your child is coming for breakfast make sure they arrive at 7:30-7:45 a.m. Our bussed students then eat from 7:45-8:00 a.m.

Please make sure your child is picked up or knows where to walk at 2:45 when the day ends. The office will not take any calls after 2:30 p.m. with messages for children. Please make these arrangements at home in the nothing. **The office closes at 3:00 p.m. daily. There is no one to watch your children after that time.**

SCHOOL CALENDAR...A copy of the school calendar is enclosed in the "First Day Envelope". Please keep this handy to help you plan vacations and the 3 hr. "Early Dismissal" days and 2 hr. Dismissal days.

BOOK RENTAL...The book rental fee for 4K is \$20.00 per year with the discounts.

The book rental fee for Kindergarten is \$28 per year.

The book rental fee for Grades 1-5 is \$34 per year.

If you have more than one student attending Giese you only need to make out one check per family.

Please make checks payable to Giese School. If you are receiving financial assistance, the book rental fee can be waived. Please request a "Book Rent Waiver Form" in the office or complete the last page of the "**Household Income Verification Form**".

HOMEWORK POLICY...Homework is an integral part of the school learning experience. Homework is assigned to help reinforce and enrich skills or activities introduced in the classroom. It is used to develop a sense of responsibility and to help inform parents of their child's area of study. The amount of homework may vary with the grade level of the child. The level of difficulty will be directed toward the average student, so some students may complete it quickly while others may take a longer period of time depending on work and study habits. Homework is expected to be completed on time.

Incomplete classroom assignments usually are not considered homework. Classroom work missed when a child is absent is expected to be made up. It is not considered homework. The policy for make-up work is:

Parents who want to pick up work for their child because of absence or illness must give the teacher some time to assemble the materials.

You must call by 9:00 a.m. if you want to pick up the work after school.

If the calls are made **after 9:00 a.m.** the work will be available the next day.

Teachers have a full classroom of students to work with and cannot drop what they are doing to get work ready to go home.

STUDENT CODE BOOKS...The Racine Unified "Code of Student Responsibilities and Rights" and the "School Behavior Guidelines" will be sent home in the "First Day Packet". The principal will review the expectations in a grade level assembly. Please go over these with your child.

HIGH SCHOOL FOOTBALL GAMES...Under Racine Unified School District policy all elementary and middle school students must be accompanied by an adult in order to be admitted to the high school football games.

INSTRUMENTAL MUSIC ...We will be recruiting students in 4th & 5th grade who want to play an instrument. There is an annual instrumental rental of \$45 per semester for students who rent school-owned instruments. Information regarding rental and fittings will be sent out to parents in the first weeks of school.

FREE LUNCH & BREAKFAST APPLICATION...All parents must fill out the new "Household Income Verification form and return it to the office as soon as possible. This form is needed to determine school-wide programs we are eligible for such as Title One & the S.A.G.E program. All students at Giese will receive free breakfast & free lunch, but the form must be turned in.

PARKING RESTRICTIONS...There is "NO PARKING" in the school turn-around. This area is reserved for school busses. Please park on the south side of Byrd Avenue. Violators who do not observe the posted signs will be ticketed. Note the new "DO NOT ENTER" sign on the west end of the parking lot. This is an "EXIT ONLY" now. You must use the driveway on the east end to enter the parking lot for Giese School. Racine Police will be ticketing cars who do not follow these new parking restrictions.

BLANKET PERMISSION FORM...Please complete the "Blanket Permission Form" enclosed in this packet and return it to school as soon as possible to your child's homeroom teacher. The blanket permission form is used for your child to go on field trips sponsored by Racine Unified such as the Gifford Planetarium, Racine Zoo, Racine Environmental Education Center, and walking field trips in the Giese area.

EARLY RELEASE DATES FOR 2015-2016
September 25, 2015-2 hr. Early Release
October 16, 2015-2 hr. Early Release
December 11, 2015-2 hr. Early Release
January 15, 2016-3 hr. Early Release
February 12, 2016-2 hr. Early Release
April 22, 2016-2 hr. Early Release
May 13, 2016-3 hr. Early Release

School will be dismissed at 11:45 a.m. for 3 hr. Early Release.
School will be dismissed at 12:45 p.m. for 2 hr. Early Release.

Lunch will be served on both 2 hr. & 3 hr. Early Release Days
.....



2015-2016 School Meal Information

Community Eligibility Provision Elementary Schools

Dr. Jones, Fratt, Giese, Goodland, Janes, Jerstad-Agerholm, Johnson, Julian Thomas, Knapp, Mitchell, North Park, RCLA, REEC, Roosevelt, Schulte, Wadewitz and West Ridge

Your child's school will be participating in the Community Eligibility Provision (CEP) for the 2015-2016 school year. Breakfast and lunch will be available to ALL children at no cost regardless of lunch status.

Students are required to take a hot pack, cold pack and fluid milk to have a complete lunch. If a child does not have all required components of the meal he/she will be asked to pay the a la carte prices for his/her items. Extra cartons of milk are \$.50 and juice is \$.45. Extra hot packs are \$1.70 and extra cold packs are \$1.10. A la carte items must be paid for regardless of lunch status. Children who bring a cold lunch may still purchase a la carte drinks at the above prices. A la carte items cannot be purchased if your child is in the negative or does not have money on their account.

Breakfast is offered at all CEP elementary schools. Please call your child's school for serving times. Breakfast includes whole grain cereal, muffin, breakfast bar, yogurt, string cheese, or similar item accompanied with whole grain graham crackers, choice of hormone-free skim milk and 100% fruit juice. Students need to take at least three (3) different items of the four (4) offered items to have a complete meal.

All lunch menus are available online at www.rusd.org or in the main office of your child's school. Your child's ending lunch balance from 2014-2015, whether positive or negative, will roll over to the 2015-2016 school year. Any negative balances from last year must still be paid.

Lunch Payments:

For a la carte items you may send payment in three ways: cash, check, or online payment. When sending your child with cash or check, **please make sure the payment is in an envelope with the child's name and room number clearly marked.** Checks can be made payable to Racine Unified School District. Teachers will collect money in the morning and all money will be sent to the kitchen for deposit. To pay online with RevTrak, go to our District website and on the upper right-hand side, select Quicklinks then Online Payments. You will need to have your student's ID number, and there is a \$1.50 convenience fee for each transaction. Payments made before 8:30 a.m. will be credited to your child's account on that day and payments made after 8:30 a.m. will be credited the following day. Please note that payment online and by check are the most secure form of payment. Negative balance letters will be sent home with elementary school students twice a week.

Please call or email the food service office for information regarding lunch money refunds.

Food Allergies:

If your child has dietary restrictions or food allergies, please contact the District dietitian Kathryn Hoff at 262-664-8701 or Kathryn.hoff@rusd.org. Proper paperwork will need to be signed by a physician and on file with the dietitian before accommodations are made.

Lunch Account Balance Emails:

Balance Alert Emails can now be sent directly to your home or work email to notify you when your child's account is getting low or is in the negative. Emails will be sent out every three days. Please email Kaitlin Wieske at kaitlin.wieske@rusd.org to sign up for these alerts and include your student(s) first and last names and the school they attend. If your email is already on file with the Food Service software, you will continue to receive the balance emails.

2015-2016 Free and Reduced Meal Applications:

Even though breakfast and lunch is served at no cost to all students, Free or Reduced Meal Applications should still be submitted for children attending a CEP school. If you have children in non-CEP buildings you should include your CEP students on the lunch application. Book Rental fees will only be waived for families complete the Sharing Information with Other Programs page.

Please contact Kaitlin Wieske at 262-631-7082 or kaitlin.wieske@rusd.org with any questions.

IMPORTANT NOTICE FROM THE ATTENDANCE OFFICE

ATTENDANCE & TARDINESS....It is very important to notify the office on our attendance phone number at **664-8255** if your child is going to be absent from school. If you do not notify us of your child's absence, we are obligated to call your home.

Wisconsin law allows for **up to 10 days** in a school year to be excused. Beyond this number of absences, medical excuses and/or written requests for absences must be provided and approved.

If your child has a medical reason for an extended absence, written documentation from a doctor is required for the absence to be excused. Any visit to a doctor, dentist, ER, or other health provider may be excused if written documentation is provided to the attendance office. These absences will not be counted toward the 10 days allowed in a school year.

The school day begins promptly at **8:00**. Students who arrive after 8:00 are considered tardy. Please help us begin our school days on time and without disruption from students who arrive late.

If your child is going to be later and needs a hot lunch, please call the main office line at 664-8250 before 9:00 a.m. to order one. Any address and/or phone number changes need to be reported to the main office.

Thank you for your help and cooperation with these matters. If you have any questions, please contact Susan Podskarbi, School Social Worker, at 664-8262.



Help Your Child Succeed in School: Build the Habit of Good Attendance Early

School success goes hand in hand with good attendance!

DID YOU KNOW?

- Starting in kindergarten, too many absences can cause children to fall behind in school.
- Missing 10 percent (or about 18 days) can make it harder to learn to read.
- Students can still fall behind if they miss just a day or two days every few weeks.
- Being late to school may lead to poor attendance.
- Absences can affect the whole classroom if the teacher has to slow down learning to help children catch up.

Attending school regularly helps children feel better about school—and themselves. Start building this habit in preschool so they learn right away that going to school on time, every day is important. Good attendance will help children do well in high school, college, and at work.

WHAT YOU CAN DO

- Set a regular bed time and morning routine.
- Lay out clothes and pack backpacks the night before.
- Find out what day school starts and make sure your child has the required shots.
- Introduce your child to her teachers and classmates before school starts to help her transition.
- Don't let your child stay home unless she is truly sick. Keep in mind complaints of a stomach ache or headache can be a sign of anxiety and not a reason to stay home.
- If your child seems anxious about going to school, talk to teachers, school counselors, or other parents for advice on how to make her feel comfortable and excited about learning.
- Develop back-up plans for getting to school if something comes up. Call on a family member, a neighbor, or another parent.
- Avoid medical appointments and extended trips when school is in session.

When Do Absences Become a Problem?

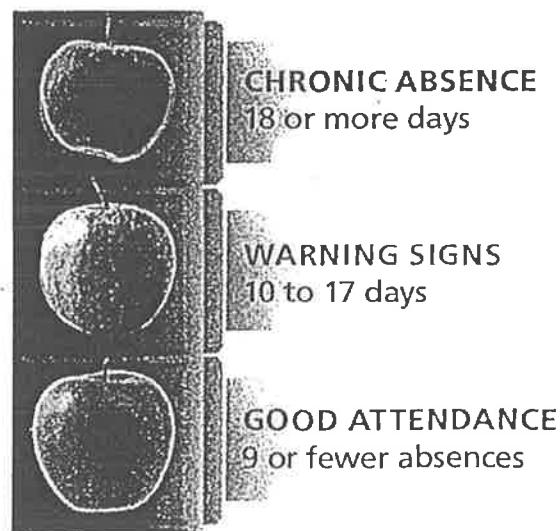

Note: These numbers assume a 180-day school year.

Welcome to Giese Elementary School

This year, Giese Elementary is turning 50!!!! In 1965, ground broke on this location to build this wonderful school. 50 years later, we have produced a many wonderful students who are amazing contributors to our society. I am truly honored to be your child's principal this year. These are a few items that I would like to make you aware of:

Attendance: Last year, only 23% of our students were regularly in school. If your child isn't in school, they aren't learning. Please help us by getting your child(ren) to school. I do understand that children do get sick and winter weather can play a factor. But, we ask that you do everything you can to have your children at school. Here at Giese Elementary we believe: "Every Child, Every Minute, Every Day". If your child is going to be sick, PLEASE call him/her into our attendance office.

Young Leaders Academy: YLA is an afterschool program that is for grades 2 through 5. The data from last year shows that the students in the YLA program did much better than students who weren't in the program. Please consider signing your student up for the YLA program.

Front Drop off Area: The front area of the school is for drop off only. Please do not park there. We have a tremendous amount of traffic that goes through this area (Parents, staff and busses). If you need to exit your car, please use the parking lot or the street to park.

Sports: We offer Co-Ed Basketball for our 4th and 5th graders (possibly 3rd; depending on the numbers). This will take place during the winter months. Games will be played at another facility (Last year it was Julian Thomas). If your child participates, they will be held accountable to a code of conduct.

Infinite Campus: Infinite Campus is our new technology system that allows you to have access to your child's grades. There will be a parent training coming soon. Please look for future information on this topic.

Finally, it truly takes all of us to have your child be successful in school. We ask that you continue to play an active role in your child's education. With you and Giese working together with your child(ren), they will be so successful. Thank you for placing your trust in us to help educate your child(ren).

"Every Child, Every Minute, Every Day"

Racine Unified School District
Annual Asbestos Notification
(2015-2016)

As a result of the federal law AHERA (Asbestos Hazard Emergency Response Act) all primary and secondary schools are required to develop and implement a plan for managing all building materials which contain asbestos. Included in the AHERA Act is the requirement to notify all parents, guardians and staff members, as well as organizations representing them, of activities and events with the asbestos containing building materials annually.

Asbestos has been used in many building materials due to its outstanding insulating and strengthening properties. When it is undisturbed or intact, it poses little hazard to human health. It is only when damage has or may occur that the quality of the school's management program becomes an issue.

In 1988, all buildings owned, leased, or "under the control of" the School District were inspected by EPA accredited inspectors, with building material samples analyzed by an independent laboratory. Based on the inspection, the School District prepared and the state approved a comprehensive management plan for administering the asbestos located within its buildings, safely and responsibly.

Once every three years, certified inspectors must re-inspect remaining materials. In addition, the rule requires a periodic walk-through (called "surveillance") in each area containing asbestos every six months.

Short-term workers (outside contractors e.g. telephone repair workers, electricians, etc.) must be provided information regarding the location of asbestos in which they may come into contact. All short-term workers shall contact the lead maintenance person before commencing work.

Within the last year, the Racine Unified School District has conducted planned asbestos removal in response to building renovations at the following school buildings:

Jerstad-Agerholm J.I. Case Wadewitz Horlick Janes McKinley

In addition, we continue to ensure our asbestos building materials are kept in good condition by continuing our Operations and Maintenance (O&M) program throughout the buildings. Racine Unified School District continues a working relationship with Environmental Management and Consulting (Lake Mills, WI) to assist us in managing our asbestos materials.

The School District has a list of the location(s) and type(s) of asbestos containing materials found in the building and a description and timetable for their proper management. A copy of the Asbestos Management Plan is available for review in the School District office as well as individual school offices. Copies are available at the School District office at a cost of twenty-five (25) cents per page. Our goal is to be in full compliance with AHERA. It is our policy to maintain a safe and healthful environment for our students and our staff members. This shall be accomplished by strict enforcement of the policies regarding asbestos by the asbestos manager and the school officials. All questions or concerns regarding the management of the asbestos within the School District should be directed to Mr. Chris Dupré, LEA Designated Person for Racine Unified School District.



BE FIRST DAY READY

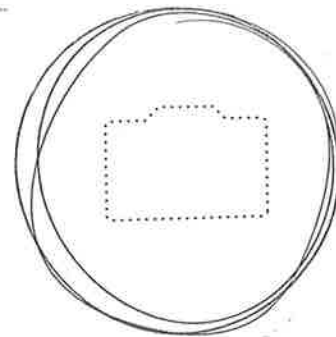
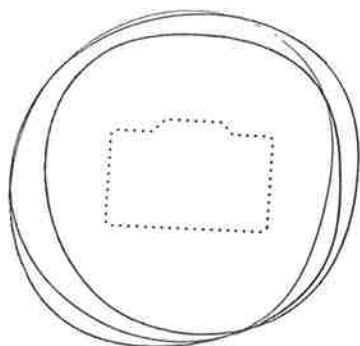
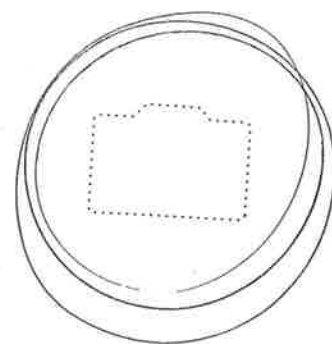
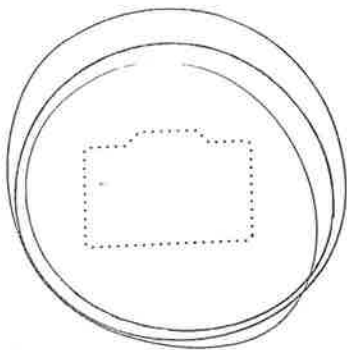

Go back to school with Box Tops and get a head start on earning for our school! Tape or paste your clipped Box Tops to this sheet and turn it into school when all the spaces are filled. Bonus Box Tops certificates must be turned in separately.

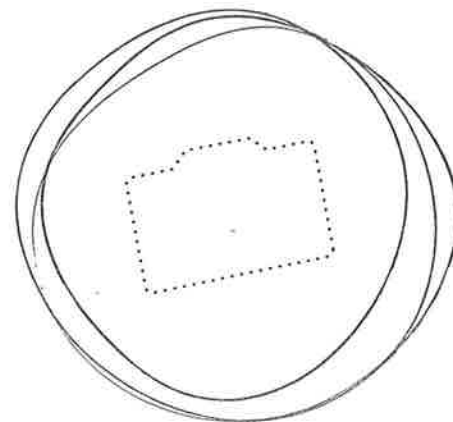
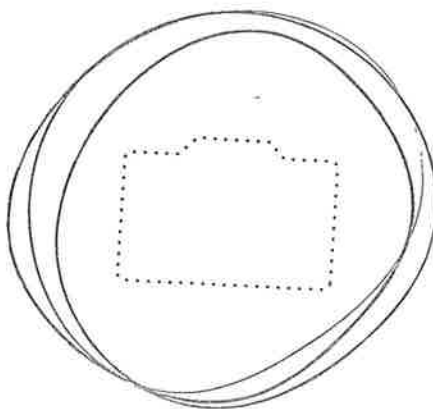
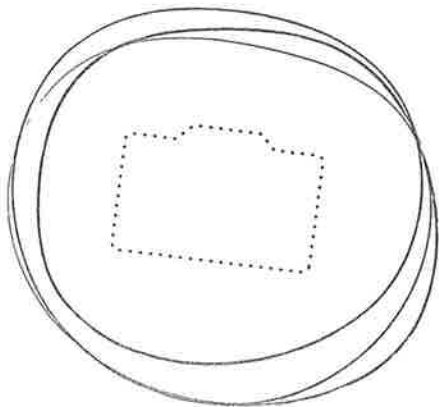
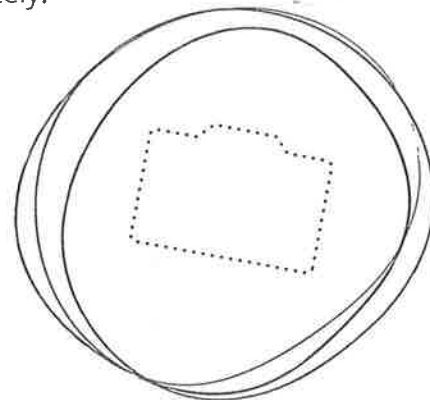
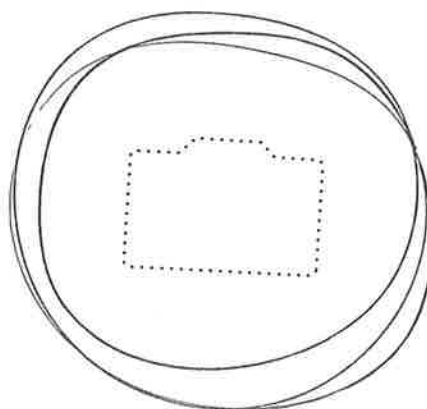
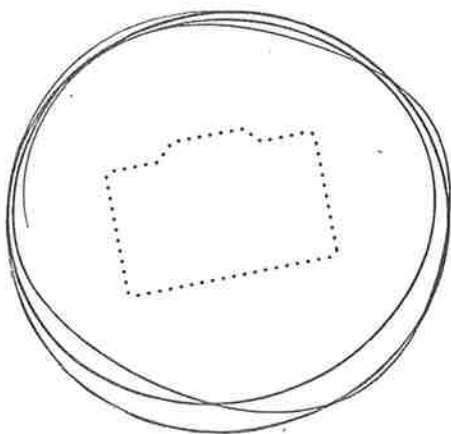

Thank you for helping! Box Tops are each worth 10¢ for our school. To learn more about Box Tops for Education, go to BTFE.com.

September 2015



Racine Unified Elementary Lunch Menu



Monday	Tuesday	Wednesday	Thursday	Friday
<p>7</p> <p>Welcome Back!</p> <p>Labor Day</p>	<p>1</p> <p>Pizza Dippers w/ Marinara Dipping Sauce Romaine Salad w/ Ranch Dressing Mandarin Oranges</p>	<p>2</p> <p>Meatball Hoagie* Sweet Garden Peas Crunchy Baby Carrots w/ Ranch Dressing 100% Pure Apple Juice</p>	<p>3</p> <p>Crispy Chicken Sandwich Baked Beans Cucumber Slices w/ Ranch Dressing Plump Raisins</p>	<p>4</p> <p>Creamy Mac 'N Cheese Steamed Carrot Coins Fresh Broccoli Buds w/ Ranch Dressing Petite Banana</p>
<p>8</p> <p>Mini Maple Pancakes Turkey Sausage Patty Baked Hash Brown 100% Mango Wango- Vegetable Juice Orange Smiles</p>	<p>9</p> <p>Fiesta Beef Nachos* Golden Sweet Corn Zesty Salsa Red Delicious Apple</p>	<p>10</p> <p>Cheese Pizza Slice Crunchy Baby Carrots Fresh Broccoli Buds w/ Ranch Dressing Petite Banana</p>	<p>11</p> <p>Spaghetti w/ Meat Sauce* & Garlic Toast Romaine Salad w/ Ranch Dressing Golden Peaches</p>	<p>18</p> <p>Cheesy Quesadilla Seasoned Green Beans Tortilla Chips w/ Zesty Salsa Red Delicious Apple</p>
<p>14</p> <p>Crispy Chicken Sandwich Golden Sweet Corn Fresh Broccoli Buds w/ Ranch Dressing Red Delicious Apple</p>	<p>15</p> <p>Pizza Dippers w/ Marinara Dipping Sauce Romaine Salad w/ Ranch Dressing Bartlett Pears</p>	<p>16</p> <p>Lucky Tray Day Salisbury Steak* w/ Gravy* Dinner Roll Whipped Potatoes Crunchy Baby Carrots Juicy Pineapple</p>	<p>17</p> <p>Mini Corn Dogs Baked Beans Crisp Celery Sticks w/ Ranch Dressing Orange Smiles</p>	<p>25</p> <p>Early Release Chef Chicken Salad w/ Ranch Dressing Goldfish Crackers Cucumber Slices 100% Pure Apple Juice</p>
<p>21</p> <p>Popcorn Chicken Dinner Roll Baked Beans Crunchy Baby Carrots w/ Ranch Dressing Fruit Medley</p>	<p>22</p> <p>Fiesta Beef Tacos* w/ Lettuce and Cheese & Taco Sauce Golden Sweet Corn Red Delicious Apple</p>	<p>23</p> <p>Spaghetti w/ Meat Sauce* & Garlic Toast Romaine Salad w/ Ranch Dressing Golden Peaches</p>	<p>24</p> <p>Cheese Pizza Slice Crisp Celery Sticks Crunchy Baby Carrots w/ Ranch Dressing Petite Banana</p>	<p>2</p> <p>Juicy Cheeseburger* Baked Beans Cucumber slices w/ Ranch Dressing Red Delicious Apple</p>
<p>28</p> <p>Chicken Nuggets w/ Seasoned Brown Rice* Romaine Salad & Cherry Tomatoes w/ Ranch Dressing Bartlett Pears</p>	<p>29</p> <p>Hot Diggity Dog Golden Sweet Corn Crunchy Baby Carrots w/ Ranch Dressing 100% Pure Apple Juice</p>	<p>30</p> <p>Pepperoni Lil' Bites Pizza Rolls w/ Marinara Dipping Sauce Fresh Cauliflower Buds w/ Ranch Dressing Mandarin Oranges</p>	<p>1 (October)</p> <p>French Toast Sticks Turkey Sausage Patty Baked Hash Brown 100% Dragon Punch- Vegetable Juice Orange Smiles</p>	

September is
Better Breakfast Month!

Take the challenge
Can you eat breakfast
EVERY DAY this month?

Make your morning easy!
Have breakfast at school—
full of whole grains and protein to
start the day right for only \$1.25!

Lunch \$2.45
(Milk included with meal)

Milk 45c
Offered Daily:
Skim White, Skim Chocolate

Questions
Call Arbor Management, Inc.
262-664-8700

Menu changes may be necessary.
Notice will be given when possible.

A comprehensive Nutrition
& Allergy Guide is available on
the Unified website.
For more information
visit www.unified.org
or to "Ask the Diabitian",
check out our website!

This menu follows USDA National School Lunch Program guidelines. USDA is an equal opportunity provider and employer. * Contains beef ingredients. Elementary menus are pork- and nut-free.



September 2015

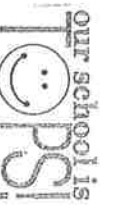

Sunday	Monday	Tuesday	Wednesday	Thursday	Friday	Saturday
LIBRARY WEEK		1 SCHOOL BEGINS "A-DAY"	2 "B-DAY"	3 Strings Demonstration Gr. 4 12:30 p.m. "C-DAY"	"A-DAY"	5
6	7 Labor Day	8 "B-DAY"	9 "C-DAY"	10 Gr. 4 to Watershed 8:30-11:00 "A-DAY"	11 "B-DAY"	12
13 LIBRARY WEEK	14 "C-DAY"	15 YLA Begins "A-DAY"	16 "B-DAY"	17 "C-DAY"	18 "A-DAY"	19
20	21 "B-DAY"	22 "C-DAY"	23 Gr. 5 to Planetarium 9:30-11:30 "A-DAY"	24 "B-DAY"	25 2 Hr. Early Release "C-DAY"	26
27 LIBRARY WEEK	28 "A-DAY"	29 "B-DAY"	30 "C-DAY"	OCTOBER 1st PICTURE DAY		