



THE CHEETAH CHATTER
W.C. Giese School



September, 2016

Volume 51

Number 1

Giese Cheetah Families,

To our returning families, welcome back! To our new families, welcome to Giese Elementary! The Staff and I are extremely excited to get the year started and hit the ground running. There are some very exciting things getting ready to happen this year!

Let me begin by first introducing myself. My name is Tom Hyland and I am the Directing Principal for Giese. This is my 3rd year at Giese and I have truly enjoy the relationships that I have made with all of you. I look forward to serving you and your children.

This year we have a new system in place for all of our families. It is called Infinite Campus. This system will allow you to have access to all sorts of information relating to your child(ren). It is crucial that we have to most accurate and up to date information regarding your child. The first step of this process is stopping by the office to pick up your GU-Id number (please bring in a photo ID as proof for security reasons)

Like last year, we are focusing on increasing your child's reading abilities. Our first effort will focus on improving of your child's *Independent Reading Time*. This year, all Giese students will be assessed at the beginning of the year to determine their Independent Reading Level per the Fountas and Pinnell Leveling System. Your child's level will come in the form of a letter (A-Z). When your child receives their letter, they will then choose books to independently read at that level. This will ensure that the books they are reading at school and home are books that they can read successfully and comprehend. Your child will then be assessed around January and once again in June. The goal is to see every child increase their Independent Reading Level and continue on the journey to becoming life-long readers. (A chart titled *Fountas and Pinnell Text Level Ladder of Progress* has been attached to this newsletter to better explain what your child's letter will mean.). Please read with your child 20 minutes a night. This will make them better readers.

We are also excited to roll out our new math curriculum to your child(ren) it is called ORIGO math. It is designed to have students work in small independent and whole classroom group. The lessons can be differentiated to have students work at a higher pace as well as giving reinforcement skills to solidify what they may need assistance on.

We need your help this year and aren't afraid to ask for it. Please consider filling out a WINGS approval form and sending it back to school with your child. Once the district approves you, please let your child's teacher know that you are interested in helping us out. Past volunteers have helped create bulletin boards, copied papers for teachers, tutored students in literacy and math, and helped assist teachers with Reading and Math Centers. Also, please consider dropping in at one of the monthly PTA meetings (dates to be sent home at a future date). Joel Schroeder is currently our PTA President. He could certainly use a couple of extra set of hands this year with all of our planned PTA activities.

FOR THE SAFETY OF OUR CHILDREN, please do not utilize the Giese Staff Parking Lot as a loading/unloading zone with your child. It can be very dangerous, especially for the younger children. Please note the new "DO NOT ENTER" signs on the west end of the Parking lot. This is an "EXIT ONLY" now. You must use the driveway on the east end to enter the parking lot for Giese School. Also, please do not park in the front turnaround as the busses and daycare vans need this space to safely load and unload their passengers. I thank you, in advance, for your cooperation.

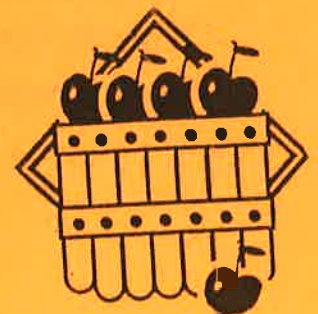

THE CHEETAH CHATTER
W.C. Giese School

September, 2016

Volume 51

Number 1

Attendance is such a critical part of your child's success. Please make every effort to have your child here on time every day. Our breakfast program begins at 7:30 and the school day starts at 8:00. If you know that your child will be late or absent, please call the school at 664-8255 and let us know. Our philosophy at Giese is "EVERY CHILD. EVERY MINUTE. EVERY DAY!!!" We do need your help with this so we all can be successful.

I hope that your child's 2016-2017 school year is the best one yet. Should you have any concerns or questions, I can be contacted at 664-8252 or via email at thomas.hyland@rusd.org. I am so looking forward to getting to know you and your child throughout the year!

Respectfully,



Thomas Hyland
Directing Principal - Giese Elementary
"The BEST kept secret in RUSD!"



IMPORTANT EMERGENCY CARD INFORMATION

It is very important that each and every Giese Family set up a Parent Portal account on the rusd.org website in order to enter your emergency card information. We no longer have paper copies and all information must be entered online. We need emergency contact numbers of who we can get ahold of if your child is ill or not picked up at the end of the day. There is also a spot to note if there is someone that you do not want to have contact with or pick up at any time. Please help us make sure that we have numbers for someone to contact in case of emergency. You first must pick up your child's activation code from the office in order to set this account up on the Parent Portal. Please bring a photo ID to school to pick up this code. If you do not have computer access at home, please come to school and we can help you get online here. Please do this as soon as possible!



IMPORTANT NOTICE FROM THE ATTENDANCE OFFICE

ATTENDANCE & TARDINESS.....It is very important to notify the office on our attendance phone number at **664-8255** if your child is going to be absent from school. If you do not ~~notify us of your child's absence, we are obligated to call your~~ home.

Wisconsin law allows for **up to 10 days** in a school year to be excused. Beyond this number of absences, medical excuses and/or written requests for absences must be provided and approved.

If your child has a medical reason for an extended absence, written documentation from a doctor is required for the absence to be excused. Any visit to a doctor, dentist, ER, or other health provider may be excused if written documentation is provided to the attendance office. These absences will not be counted toward the 10 days allowed in a school year.

The school day begins promptly at **8:00**. Students who arrive after 8:00 are considered tardy. Please help us begin our school days on time and without disruption from students who arrive late.

If your child is going to be later and needs a hot lunch, please call the main office line at 664-8250 before 9:00 a.m. to order one. Any address and/or phone number changes need to be reported to the main office.

Thank you for your help and cooperation with these matters. If you have any questions, please contact Susan Podskarbi, School Social Worker, at 664-8262.



Help Your Child Succeed in School: Build the Habit of Good Attendance Early

School success goes hand in hand with good attendance!

DID YOU KNOW?

- Starting in kindergarten, too many absences can cause children to fall behind in school.
- Missing 10 percent (or about 18 days) can make it harder to learn to read.
- Students can still fall behind if they miss just a day or two days every few weeks.
- Being late to school may lead to poor attendance.
- Absences can affect the whole classroom if the teacher has to slow down learning to help children catch up.

Attending school regularly helps children feel better about school—and themselves. Start building this habit in preschool so they learn right away that going to school on time, every day is important. Good attendance will help children do well in high school, college, and at work.

WHAT YOU CAN DO

- Set a regular bed time and morning routine.
- Lay out clothes and pack backpacks the night before.
- Find out what day school starts and make sure your child has the required shots.
- Introduce your child to her teachers and classmates before school starts to help her transition.
- Don't let your child stay home unless she is truly sick. Keep in mind complaints of a stomach ache or headache can be a sign of anxiety and not a reason to stay home.
- If your child seems anxious about going to school, talk to teachers, school counselors, or other parents for advice on how to make her feel comfortable and excited about learning.
- Develop back-up plans for getting to school if something comes up. Call on a family member, a neighbor, or another parent.
- Avoid medical appointments and extended trips when school is in session.

When Do Absences Become a Problem?

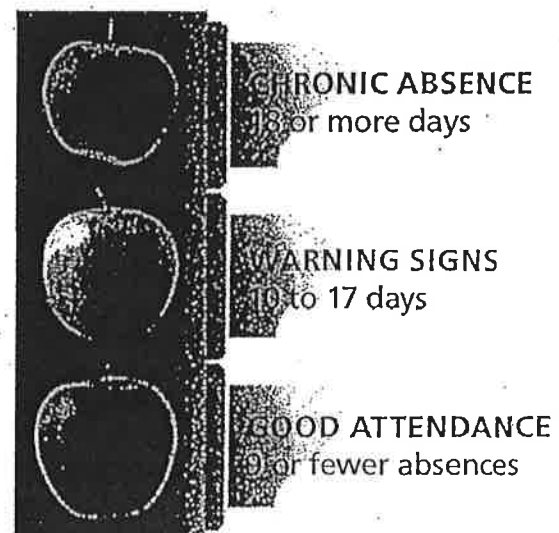

Note: These numbers assume a 180-day school year.

Welcome to Giese Elementary School

This year, Giese Elementary is turning 50!!!! In 1965, ground broke on this location to build this wonderful school. 50 years later, we have produced a many wonderful students who are amazing contributors to our society. I am truly honored to be your child's principal this year. These are a few items that I would like to make you aware of:

Attendance: Last year, only 23% of our students were regularly in school. If your child isn't in school, they aren't learning. Please help us by getting your child(ren) to school. I do understand that children do get sick and winter weather can play a factor. But, we ask that you do everything you can to have your children at school. Here at Giese Elementary we believe: "Every Child, Every Minute, Every Day". If your child is going to be sick, PLEASE call him/her into our attendance office.

Young Leaders Academy: YLA is an afterschool program that is for grades 2 through 5. The data from last year shows that the students in the YLA program did much better than students who weren't in the program. Please consider signing your student up for the YLA program.

Front Drop off Area: The front area of the school is for drop off only. Please do not park there. We have a tremendous amount of traffic that goes through this area (Parents, staff and busses). If you need to exit your car, please use the parking lot or the street to park.

Sports: We offer Co-Ed Basketball for our 4th and 5th graders (possibly 3rd; depending on the numbers). This will take place during the winter months. Games will be played at another facility (Last year it was Julian Thomas). If your child participates, they will be held accountable to a code of conduct.

Infinite Campus: Infinite Campus is our new technology system that allows you to have access to your child's grades. There will be a parent training coming soon. Please look for future information on this topic.

Finally, it truly takes all of us to have your child be successful in school. We ask that you continue to play an active role in your child's education. With you and Giese working together with your child(ren), they will be so successful. Thank you for placing your trust in us to help educate your child(ren).

"Every Child, Every Minute, Every Day".



BE FIRST DAY READY

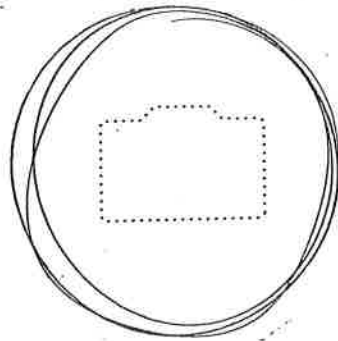
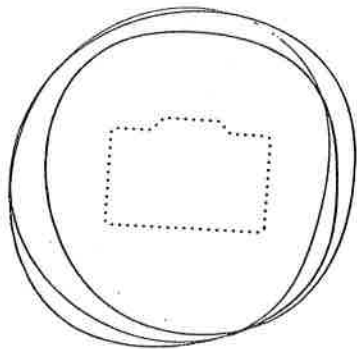
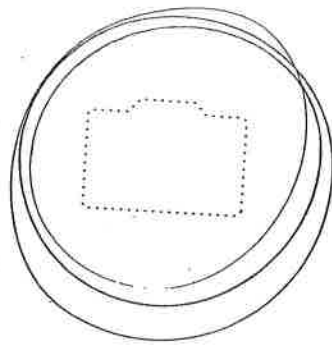
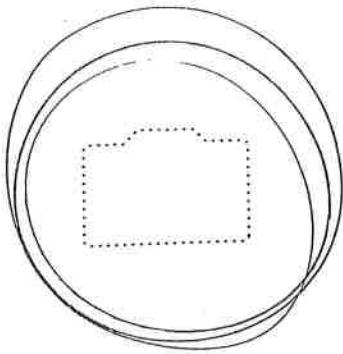

Go back to school with Box Tops and get a head start on earning for our school!
Tape or paste your clipped Box Tops to this sheet and turn it into school when all the spaces are filled. Bonus Box Tops certificates must be turned in separately.

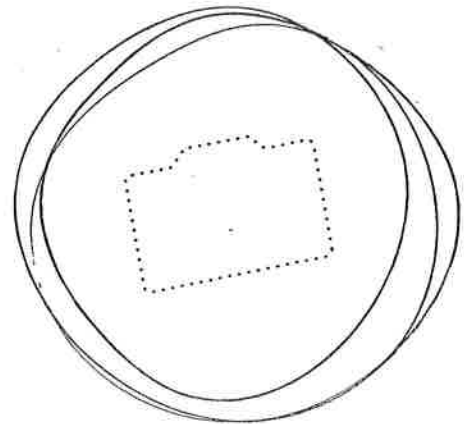
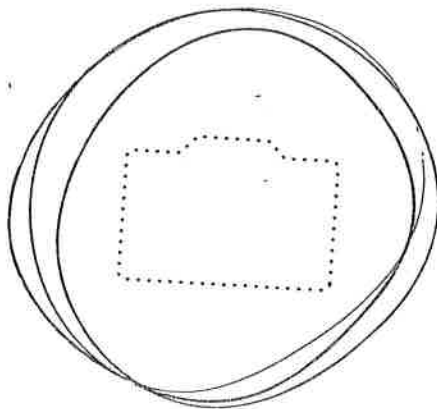
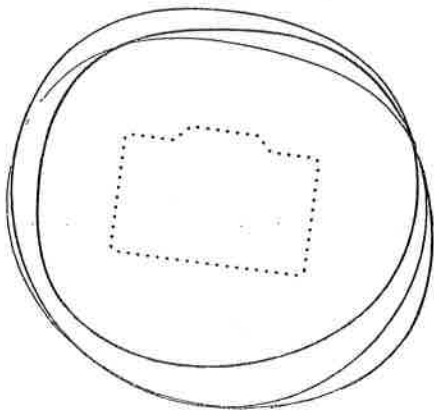
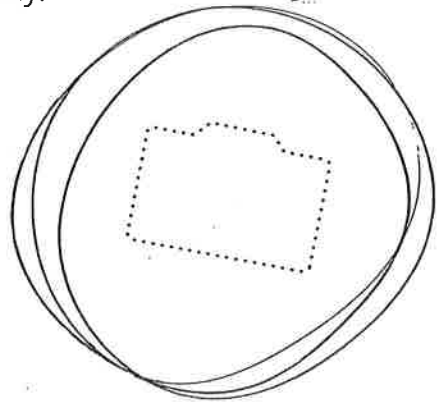
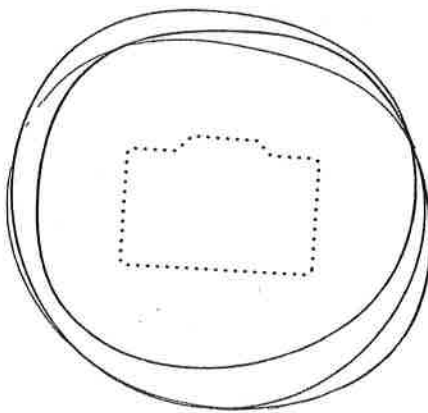
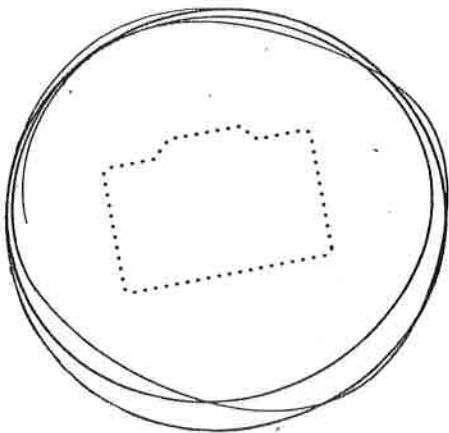

Thank you for helping! Box Tops are each worth 10¢ for our school.
To learn more about Box Tops for Education, go to BTFE.com.



2016-2017 School Meal Information

Community Eligibility Provision Elementary Schools Dr. Jones, Fratt, Giese, Goodland, Janes, Jerstad-Agerholm, Johnson, Julian Thomas, Knapp, Mitchell, North Park, RCLA, REEC, Roosevelt, Schulte, Wadewitz and West Ridge

Your child's school will be participating in the Community Eligibility Provision (CEP) for the 2016-2017 school year. Breakfast and lunch will be available to ALL children at no cost regardless of lunch status.

Students are required to take a hot pack, cold pack and fluid milk to have a complete lunch. If a child does not have all required components of the meal he/she will be asked to pay the a la carte prices for his/her items. Extra cartons of milk and juice are \$.45. Extra hot packs are \$1.70 and extra cold packs are \$1.10. A la carte items must be paid for regardless of lunch status. Children who bring a cold lunch may still purchase a la carte drinks at the above prices. A la carte items cannot be purchased if your child is in the negative or does not have money on their account.

Breakfast is offered at all CEP elementary schools. Please call your child's school for serving times. Breakfast includes whole grain cereal, muffin, breakfast bar, yogurt, string cheese, or similar item accompanied with whole grain graham crackers, choice of hormone-free skim milk and 100% fruit juice. Students need to take at least three (3) different items of the four (4) offered items to have a complete meal.

All lunch menus are available online at www.rusd.org or in the main office of your child's school. Your child's ending lunch balance from 2015-2016, whether positive or negative, will roll over to the 2016-2017 school year. Any negative balances from previous school years must still be paid.

Lunch Payments:

For a la carte items you may send payment in three ways: cash, check, or online payment. When sending your child with cash or check, **please make sure the payment is in an envelope with the child's name and room number clearly marked.** Checks can be made payable to Racine Unified School District. Teachers will collect money in the morning and all money will be sent to the kitchen for deposit. To pay online with RevTrak, go to our District website and on the upper right-hand side, select Quicklinks then Online Payments. You will need to have your student's ID number, and there is a \$1.50 convenience fee for each transaction. Payments made before 8:30 a.m. will be credited to your child's account on that day and payments made after 8:30 a.m. will be credited the following day. Please note that payment online and by check are the most secure form of payment. Negative balance letters will be sent home with elementary school students twice a week.

Please call or email the food service office for information regarding lunch money refunds.

Food Allergies:

If your child has dietary restrictions or food allergies, please contact the District dietitian at 262-664-8701 or dietitian@rusd.org. Proper paperwork will need to be signed by a physician and on file with the dietitian before accommodations are made.

Lunch Account Balance Emails:

Balance Alert Emails can now be sent directly to your home or work email to notify you when your child's account is getting low or is in the negative. Emails will be sent out every three days. Please email the Food Service Department at food.service@rusd.org to sign up for these alerts and include your student(s) first and last names and the school they attend. If your email is already on file with the Food Service software, you will continue to receive the balance emails.

2016-2017 Free and Reduced Meal Applications:

Even though breakfast and lunch is served at no cost to all students, Free or Reduced Meal Applications should still be submitted for children attending a CEP school. If you have children in non-CEP buildings you should include your CEP students on the lunch application. Book Rental fees will only be waived for families complete the Sharing Information with Other Programs page.

Please contact the Food Service Department at 262-631-7082 or food.service@rusd.org with any questions.



Racine Unified School District
Annual Asbestos Notification
(2016-2017)

As a result of the federal law AHERA (Asbestos Hazard Emergency Response Act) all primary and secondary schools are required to develop and implement a plan for managing all building materials which contain asbestos. Included in the AHERA Act is the requirement to notify all parents, guardians and staff members, as well as organizations representing them, of activities and events with the asbestos containing building materials annually.

Asbestos has been used in many building materials due to its outstanding insulating and strengthening properties. When it is undisturbed or intact, it poses little hazard to human health. It is only when damage has or may occur that the quality of the school's management program becomes an issue.

In 1988, all buildings owned, leased, or "under the control of" the School District were inspected by EPA accredited inspectors, with building material samples analyzed by an independent laboratory. Based on the inspection, the School District prepared and the state approved a comprehensive management plan for administering the asbestos located within its buildings, safely and responsibly.

Once every three years, certified inspectors must re-inspect remaining materials. In addition, the rule requires a periodic walk-through (called "surveillance") in each area containing asbestos every six months.

Short-term workers (outside contractors e.g. telephone repair workers, electricians, etc.) must be provided information regarding the location of asbestos in which they may come into contact. All short-term workers shall contact the lead maintenance person before commencing work.

Within the last year, the Racine Unified School District has conducted planned asbestos removal in response to building renovations at the following school buildings:

- McKinley Horlick North Park Gifford Olympia Brown Mitchell
- Old Knapp (prior to demolition)

In addition, we continue to ensure our asbestos building materials are kept in good condition by continuing our Operations and Maintenance (O&M) program throughout the buildings. Racine Unified School District continues a working relationship with Environmental Management and Consulting (Lake Mills, WI) to assist us in managing our asbestos materials.

The School District has a list of the location(s) and type(s) of asbestos containing materials found in the building and a description and timetable for their proper management. A copy of the Asbestos Management Plan is available for review in the School District office as well as individual school offices. Copies are available at the School District office at a cost of twenty-five (25) cents per page. Our goal is to be in full compliance with AHERA. It is our policy to maintain a safe and healthful environment for our students and our staff members. This shall be accomplished by strict enforcement of the policies regarding asbestos by the asbestos manager and the school officials. All questions or concerns regarding the management of the asbestos within the School District should be directed to Mr. Chris Dupré, LEA Designated Person for Racine Unified School District.

September 2016



Racine Unified Elementary Lunch Menu

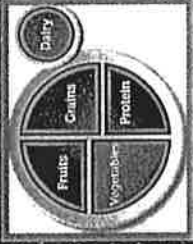

Monday	Tuesday	Wednesday	Thursday	Friday
5 Labor Day	6 Popcorn Chicken Baked Beans Pretzel Nugget Roll Cucumber Slices Juicy Pineapple	7 Sausage, Egg & Cheese Burrito Baked Hash Brown Orange Smiles 100% Vegetable Juice	8 Hot Diggity Dog Baked Tator Tots Cherry Tomatoes 100% Apple Juice	9 Fiesta Beef Nachos* w/Lettuce & Cheese Golden Sweet Corn Tortilla Chips w/Zesty Salsa Red Delicious Apple
12 Cheese Ravioli v w/ Spaghetti Sauce & Garlic Toast Cucumber Slices Petite Banana	13 Lucky Tray Day Chicken & Gravy Whipped Potatoes Pretzel Nugget Roll Crunchy Baby Carrots w/Ranch Dressing Fruit Medley	14 Turkey Pancake Wrap w/Syrup Baked Hash Brown Orange Smiles 100% Vegetable Juice	15 Juicy Cheeseburger* Baked Beans Crunchy Baby Carrots w/Ranch Dressing Red Delicious Apple	16 Early Release Turkey & Cheese Sub Celery Sticks w/ Ranch Dressing Crunchy Baby Carrots 100% Apple Juice
19 Pizza Dippers v w/Marinara Dipping Sauce Steamed Broccoli Cucumber Slices Red Delicious Apple	20 Mini Corn Dogs Baked Beans Crunchy Celery Sticks w/Ranch Dressing Bartlett Pears	21 French Toast Sticks Turkey Sausage Patty Baked Hash Brown Orange Smiles 100% Vegetable Juice	22 Spaghetti & Meat Sauce* w/Garlic Toast Romaine Salad w/Ranch Dressing Juicy Peaches	23 Beef Tacos* w/Lettuce & Cheese Taco Sauce Golden Sweet Corn Fresh Pear
26 Cheese Pizza Slice v Crunchy Baby Carrots w/Ranch Dressing Fresh Broccoli Petite Banana	27 Crispy Chicken Sandwich Baked Beans Cucumber Slices Juicy Pineapple	28 Waffle with Turkey Sausage Patty Baked Hash Brown Orange Smiles 100% Vegetable Juice	29 Pepperoni Lil'Bites Pizza Rolls Peas Dipping Sauce 100% Apple Juice	30 Salisbury Steak* Whipped Potatoes Dinner Roll Crunchy Baby Carrots Bartlett Pears

September is
Better Breakfast Month!

Take the challenge
Can you eat breakfast
EVERY DAY this month?

Make your morning easy!
Have breakfast at school—
full of whole grains and protein to
start the day right!

Lunch \$2.55
(Milk included with meal)

Milk 45c
Offered Daily
Skim/White, Skim Chocolate

Questions
Call Arbor Management, Inc.
262-664-8700

Menu changes may be necessary.
Notice will be given when possible.

A comprehensive Nutrition
& Allergy Guide is available on
the Unified website.

For more information
or to "ask the Dietitian"
check out our website!



September 2016

Sunday	Monday	Tuesday	Wednesday	Thursday	Friday	Saturday
			Open House 5:00-7:00	1	2	3
4	5 No School Labor Day	6 1st Day for 4K	7	8	9	10
		C-Day	A-Day	B-Day	C-Day	
11	12	13	14	15	16 *2 hr. Early Release	17
Library Week	A-Day	B-Day	C-Day	A-Day	B-Day	
18	19 Grade 4 Field Trip 8:45-11:00	20	21	22	23	24
	C-Day	A-Day	B-Day	C-Day	A-Day	
25	26	27 Gr. 5 to Planetarium 9:30-11:45	28	29	30 No School Staff Development	
Library Week	B-Day	C-Day	A-Day	B-Day		
		2P.T.A. BBQ 4:00-5:30 More details to follow				*Picture Day will be October 6 th